

D1024+/D1524+

Lithium Battery Pack Equalizer & Analyzer

User Manual

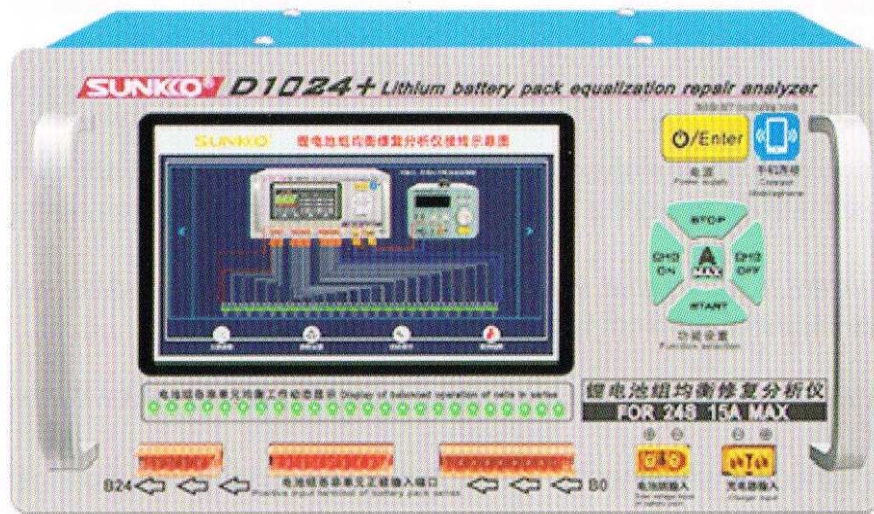

Thanks for choosing SUNKKO series produces. It will bring you convenience and efficiency for spot welding work. For optimal user experience, please read the manual carefully before using and store it properly for future reference. SUNKKO has the right to upgrade the machine and modify the manual without prior notice. Thanks for understanding!

Summarizes

D1524+ Lithium Battery Pack Equalizer & Analyzer uses the latest large-scale and high-speed MCU chips from Microchip Technology Inc. in the United States to precisely detect various units of lithium battery packs in real-time. The chip can store, process, and compare the collected voltage data, and then display the results on the screen. This equalizer can simultaneously detect the voltage situation of up to 24 strings lithium batteries, automatically analyze and compare the voltage. It has the characteristics of high accuracy, strong timeliness, simple operation, and practical reliability.

Features

- 1 The machine can automatically collect and analyze the voltage of each string of lithium battery packs, while monitoring the changes in voltage of each string of battery packs during the equalization process.
- 2 The main control chip is an intelligent MCU chip, which can automatically analyze the battery, control the battery to charge and discharge, and then start the equalization work.
- 3 You can use Bluetooth to connect to your phone and remotely control it through an app program, achieving simple and efficient work.
- 4 The internal component layout is reasonable and equipped with a heat dissipation and cooling system, which can effectively avoid the impact of high temperature environment on electronic components.
- 5 The equalization current is adjustable, with a maximum value of 15A, and the machine can accurately equalize repair of different types of battery packs.
- 6 Multiple parameters can be set to adapt to different types of battery packs for personalized equalize setting.
- 7 Simulate testing in various environments and equipped with a more comprehensive security protection setting system.
- 8 Discharge equalization: Based on the aging degree and equalization demand of the battery pack, users can choose to switch between continuous discharge equalization mode or pulse discharge equalization mode.

Product parameters

Product Name	Lithium Battery Pack Equalizer & Analyzer	Product Model	D1024+/D1524+
Voltage	AC110V~220V	Dimensions	275X242X140mm
Application	Li-ion/LifePO ₄ /LTO	Battery pack strings	2- 24 strings
Minimum balanced voltage	1mv	Maximum balanced current	10A/15A(Optional)
Start charge equalization strings / voltage	More than 10 strings/30V	Charging connection	XT-60

Application

Widely used to detect and analyze the voltage of multiple strings of batteries in various research institutions, lithium battery distributors, battery pack manufacturers, and battery protection system production units, as well as to repair the power battery pack for electric vehicles and power tools, etc.

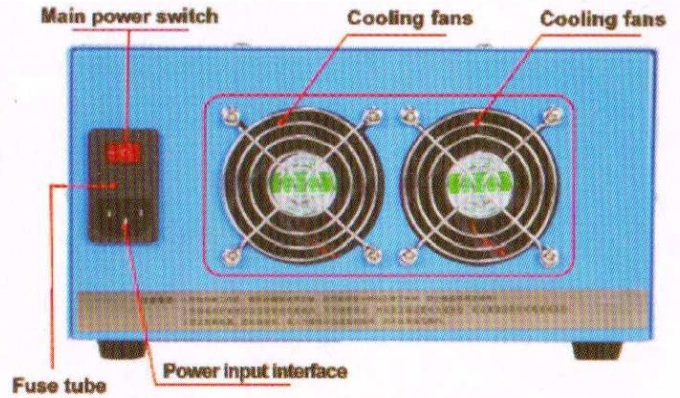
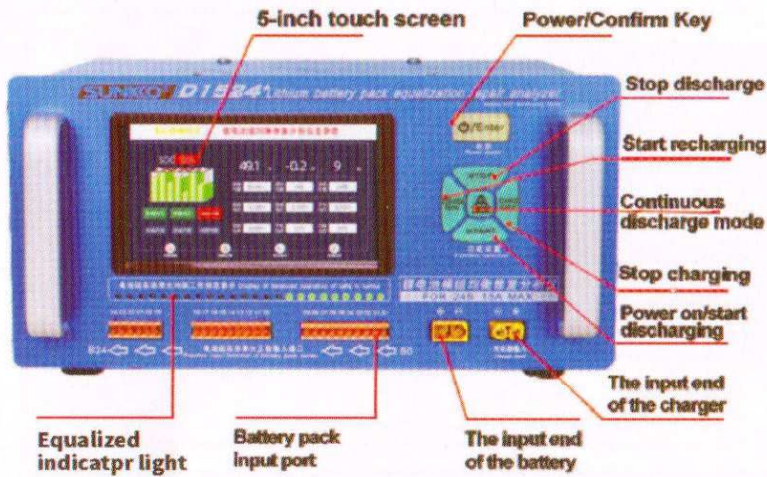

Line sequence test board

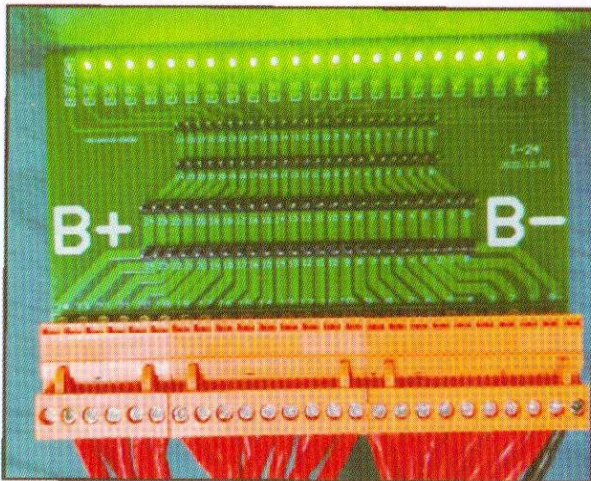

Attention: Reverse wiring sequence:
It is necessary to use a multimeter to measure the voltage between the corresponding string and adjacent strings of LED lights with abnormal brightness, identify the incorrect wire sequence, and adjust it to be correct before connecting the equalizer to start operation.

Correct wiring sequence

When the battery pack is connected in the correct wiring sequence, the corresponding string of LED lights will light up.

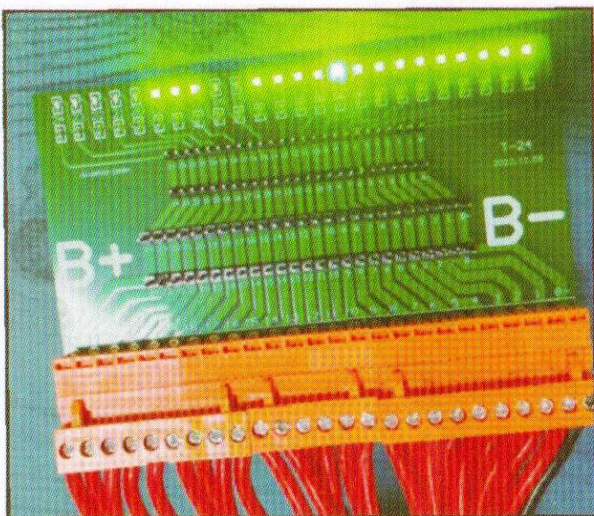

Reverse wiring sequence

When connecting the battery pack, there is a wire sequence error (such as reverse wiring sequence), and the corresponding indicator light does not light up.

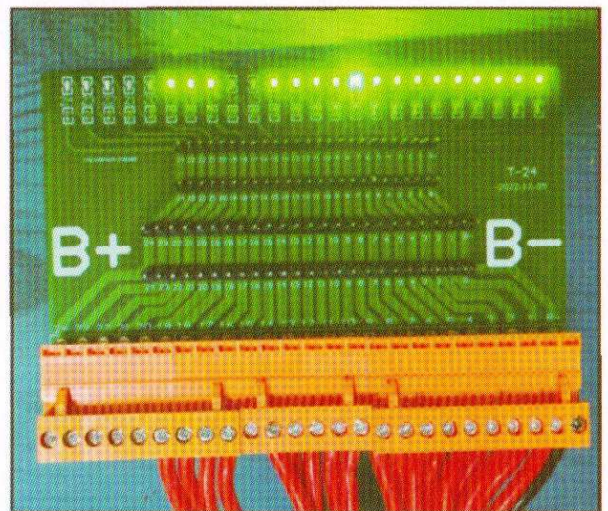

Connected battery pack with problems

When connecting the battery pack, if one of the batteries in the battery pack is damaged without voltage or if there is a faulty soldering in the battery pack, the corresponding indicator light does not light up.

Wiring diagram

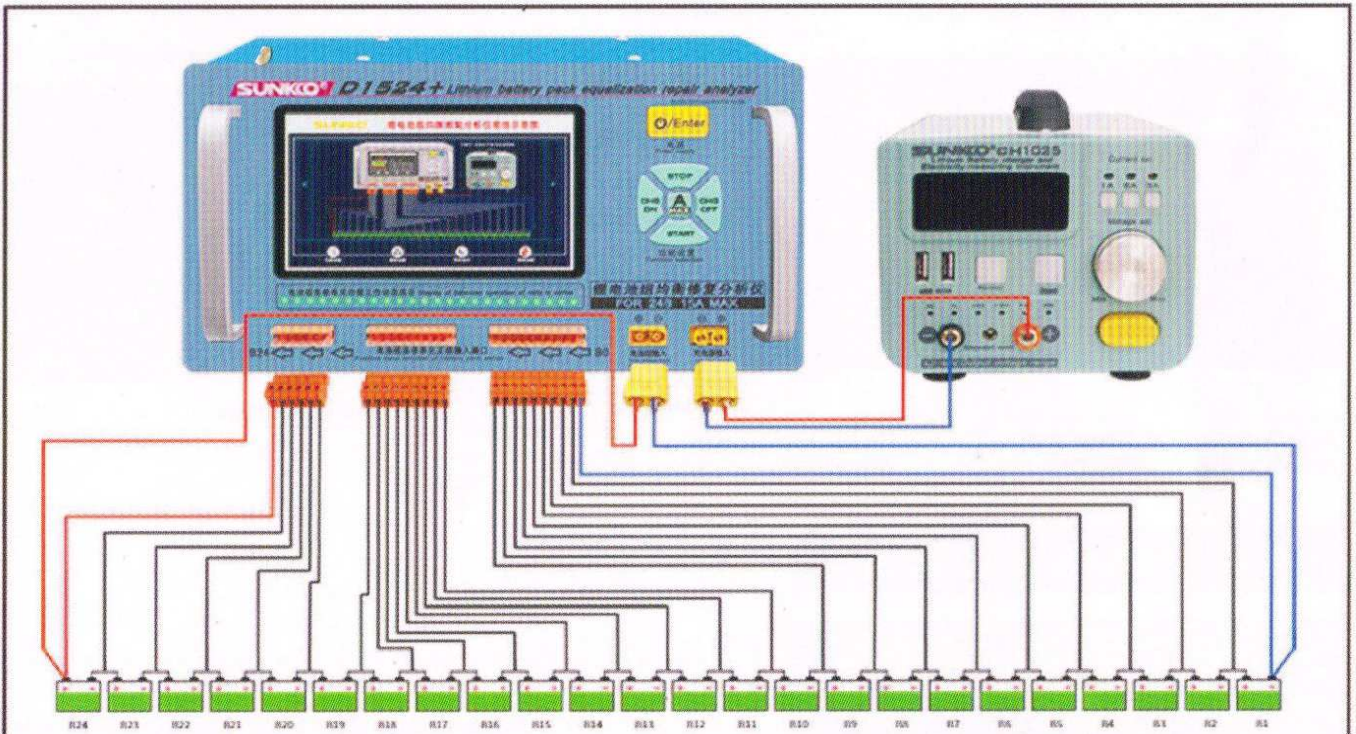

Wiring diagram of charge equalization mode

The connection method of 24 batteries in series is shown in the figure
The charging balance mode is suitable for battery packs with
10-24 batteries connected in series

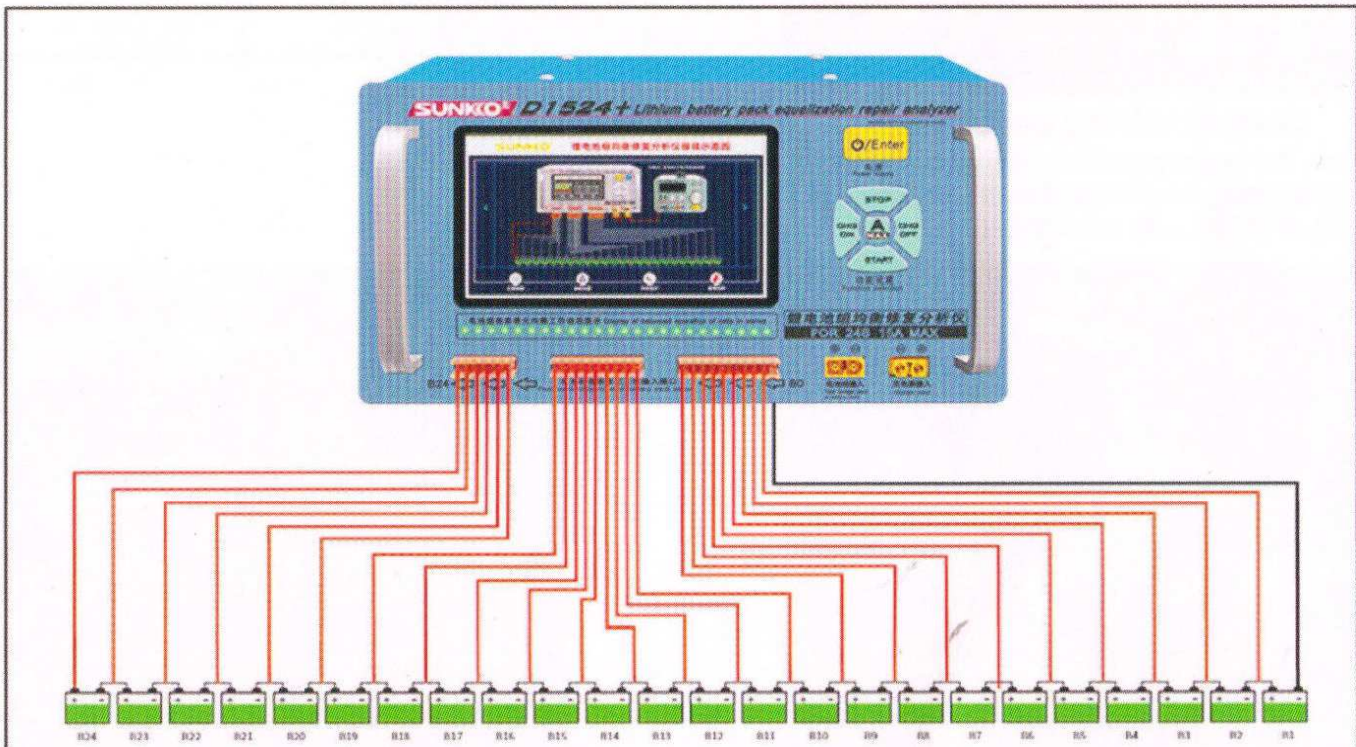

Wiring diagram of discharge equalization mode

The connection method of 24 batteries in series is shown in the figure, The discharging
balance mode is suitable for battery packs with 2-24 batteries connected in series)

Discharge equalization mode



1. There are paste labels with string number at the cable clamp, please connect the battery packs in sequence (Black wire connected to the main negative electrode of the battery pack)

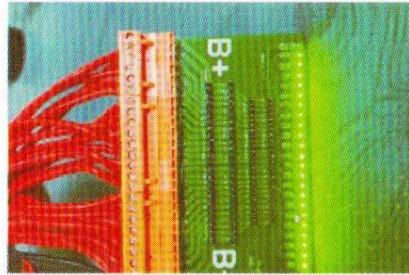

2. After the cable clamp is correctly connected to the battery pack, use a line sequence board for testing the wiring sequence. (Please check the steps for using the wire sequence board on page 2)

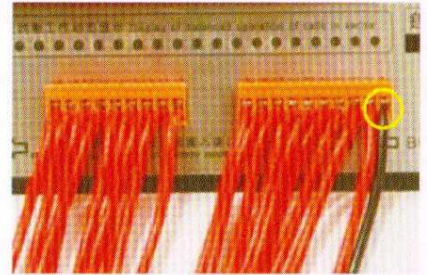

3. Connect the equalizer after ensuring the correct wiring sequence, the black wire of the main negative electrode must be located at B0 of the equalizer

Installation start-up and basic operation instructions

Set parameters



1. Power-up: Press the " " button at the back of the machine to turn on the main power switch.

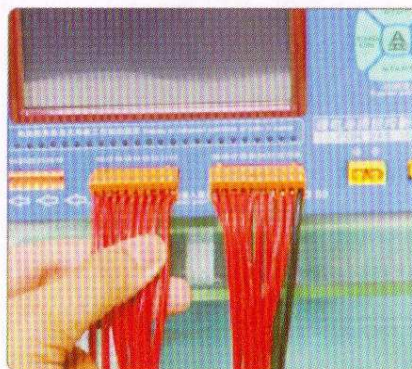

2. Please connected to the battery pack correctly. (Attention: The sequence of positive and negative poles in the battery pack wiring must be consistent with the sequence of positive and negative poles in the equalizer to avoid equipment damage.)



3. After turning on the main power switch, briefly press the " " button to start the control display screen.

Discharge equalization mode



1. Press the "START" button to start the machine battery monitoring system and automatically detect and analyze voltage of battery pack and other information.



2. Click on "Parameter Settings" and select the type of lithium battery pack connected.



3. Enter the actual number of strings connected to the battery pack, and press the "Synchronize data to BMS" button.

Discharge equalization mode

MicroCharge



1. Set the "equilibrium limit" parameter based on the voltage status of the battery pack. The machine will automatically turn on discharge equalization when the voltage exceeds the set value

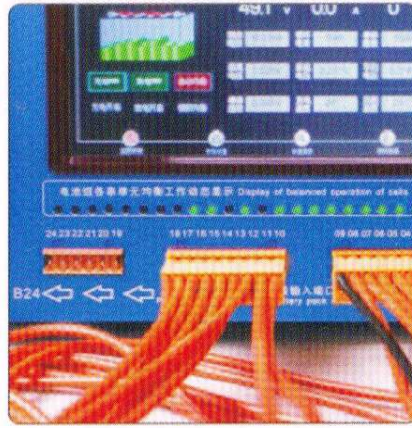

2. The corresponding string number indicator light will flash in discharge equalization mode, and the light will go out when the equalization is over



3. During the equalization process, pressing the "STOP" button can stop the equalization.

Switch to the discharge mode

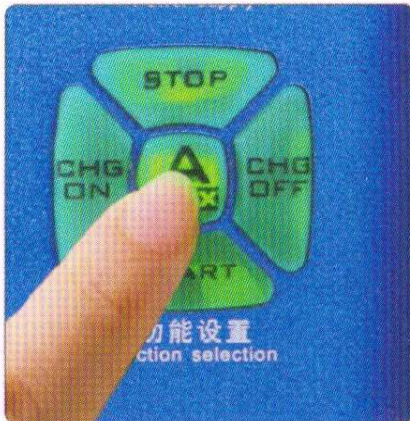

1. Press the 'A MAX' button, and the button light will flash. The machine will switch to continuous discharge mode.



2. Press the "START" key after switching to the discharge mode, and the machine will be in discharge equalization. The corresponding indicator lights will remain on until the discharge equalization is finished, the indicator light will turn off.

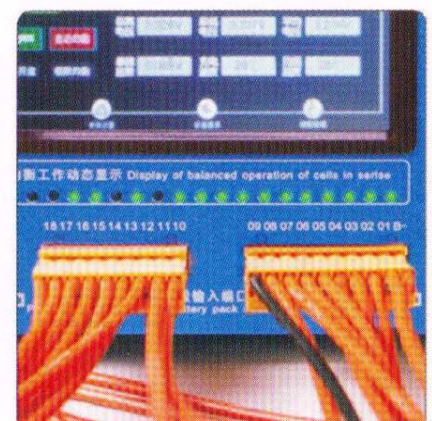

3. Press the "A MAX" button again, the button light will turn off, and the machine will switch to pulse discharge mode. Before switching modes, please press the "STOP" button to stop the equalization work.

Charge Equalization Mode



1. Charging Cable Receptacle is welded to the total positive and negative electrodes of the battery, used to connect the equalizer.

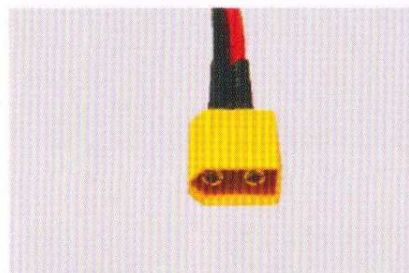

2. Charging Cable Plug is welded to adapter or charger and connected to the input port of the equalizer.



3. Connect schematic diagram

Charge Equalization Mode

MicroCharge



1. The total positive and negative poles of the battery need to be connected to the machine (left interface), and the charger needs to be connected to the input terminal (right interface) in charging mode.



2. Press the "CHG ON" button to start the charge equalization mode according to the set parameter.



3. Press the "CHG OFF" button to stop the Charge Equalization Mode.

蓝牙手机连接步骤



Search "Shenzhou Anbang Merchant Edition" in WeChat applet



1. Before connecting the Bluetooth of the mobile phone, please make sure that the machine is in working condition. (The light of the "START" button is on)



2. Turn on the Bluetooth of the mobile phone, click on the device list in the upper right corner of the applet, and find the machine with the name prefix ANT.

Parameter setting of Lithium Battery Pack Equalizer & Analyzer

SUNKKO® Lithium Battery Equalizer & Analyzer Parameters Set

The screenshot shows the following parameters and controls:

- Main Parameters:** PhysicalAh (100.0Ah), CellNumber (15S), CellHighPRT (3.600V), CellHighRCV (3.400V), CHG Over (60°C), CHG Low (-2°C).
- Parameters Set:** Remain.Ah (100.0Ah), Loop.Ah (4294Ah), CellLowPRT (2.600V), CellLowRCV (3.000V), Load Over (60°C), Load Low (-10°C).
- Status Display:** TotalVoltage (87.6V), TotalVoltage (0.0V), CellDiffON (0.002V), BalCurrent (100%), Switch To Li-ion, Switch To LiFePO4, Switch To LTO.
- User Guide:** ChargeOC (50.0A), DischargeOC (300.0A), CellBalLimit (3.100V), CellBalStart (3.000), System Restart.

The following parameters need to be adjusted before starting equalization

Ternary Lithium Battery:	set as the default parameter for ternary lithium batteries with one button
LiFePO4:	set as the parameter for LiFePO4 batteries with one button
LTO:	set as the parameter for lithium titanate batteries with one button
Number of Strings:	the actual number of strings of battery packs connected to the Equalizer & Analyzer.
Balance Limit:	Discharge equalization is started when the individual voltage is higher than the set value, and discharge equalization is stopped when it is equal to or less than this value.
Equilibrium pressure difference:	Allowable differential pressure at the end of equalization
Balance Current:	The proportion of discharge current during the equalization process. (The smaller the proportion, the more accurate the equalization.)

Three step settings make it easy to turn on equalization.

- 1 Choose the type of battery: ternary lithium, LiFePO4 or LTO.
- 2 Set the number of Strings: Enter the actual number of strings connected to the battery pack.
- 3 Set the Balance Limit: Suggest setting this value to 0.5V lower than the minimum voltage of the single battery pack.

The following parameters are factory adjustment and no need to adjust during normal use.

Total Voltage Overvoltage:It enters the protection state when the total voltage of the battery pack exceeds this value and Charging MOS is forcibly shut down.

Total Voltage Undervoltage:It enters the protection state when the total voltage of the battery pack is lower than this value, and discharging MOS is forcibly shut down.

Single cell Overvoltage:It enters the protection state when the single battery voltage exceeds this value, and charging MOS is forcibly shut down.

Overvoltage Recovery:It is in unprotected status when the single battery voltage falls back to this value, and charging MOS will restart.

Single cell undervoltage : It is in protected status when the single cell voltage is lower than this value, and discharging MOS will forcibly shut down.

Undervoltage recovery:When the single cell voltage returns to this value, the protection state is released and the discharge MOS will restart.

Charge Over Temp:It is in protected status when the internal temperature of the machine is higher than this value, and charging MOS is forcibly shut down

Charge Low Temp.:It is in protected status when the internal temperature of the machine is below this value, and charging MOS is forcibly shut down.

Discharge Over Temp.:It is in protected status when the internal temperature of the machine is higher than this value, and discharging MOS is forcibly shut down.

Discharge Low Temp.:It is in protected status when the internal temperature of the machine is below this value, and discharging MOS is forcibly shut down.

Charge Overcurrent :It is in protected status when the charging current exceeds this value, and charging MOS is forcibly shut down.

Discharge Overcurrent:It is in protected status when the charging current exceeds to this value, and discharging MOS is forcibly shut down.

Display interface

D1524+ has four display modules(Main Parameters,Parameters Set,Status Display,User Guide)

(1) Main Parameters interface



(2) Parameter Setting interface



(3) Status Display interface

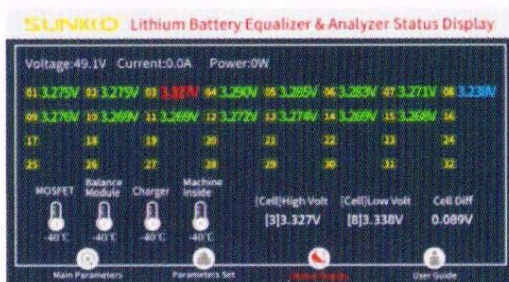

(4) User Guide interface

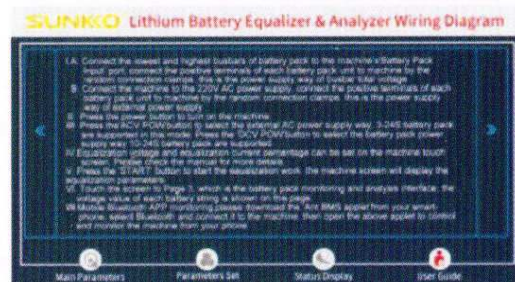

Equilibrium Principle

Discharge

Charge



Voltage disequilibrium

If the battery pack is used for a long time, the voltage becomes uneven.

Discharge equalization

Each battery string is discharged to the set minimum voltage.

Charge equalization

Stabilize the current during charging to avoid overcharging.

Second Discharge equalization

In order to achieve better equalization effect, it is recommended to continue discharging again.

Second charge equalization

Stabilize the current during charging

Notes in the Use

A. Important reminder

- 1 Please choose a equalization mode that matches the battery type or corresponds to the voltage setting when setting parameters, otherwise the responsibility for damaging the battery module will be borne by the user (2.8V for ternary lithium battery; 2.5V for Lithium iron phosphate battery)
- 2 Before connecting the equalizer to the battery module, it is required to connect the attached LED line sequence indicator board for testing. After confirming the correct polarity and phase sequence, it can be connected to the equalizer;
- 3 When connecting the equalizer to the battery module, it is necessary to pay attention to the polarity and sequence of the battery pack to meet the output terminal requirements of the equalizer. If connected incorrectly it can damage the equalizer and cause internal discharge components to burn in severe cases.
- 4 For battery modules with a capacity less than 10AH, it is required to set the balancing current to be less than 10A during operation based on the safety factors and balancing accuracy of the battery module
- 5 When equalizing the battery module, the equalizer must be placed in a ventilated environment because of the large amount of thermal energy generated due to energy consumption balancing. It is strictly prohibited to insert foreign objects or metal objects in the heat dissipation area behind the equalizer case, otherwise it may cause the instrument to explode during balancing operation.
- 6 It is necessary to pay attention to the polarity and voltage of the charging power output that match the balance instrument in charge and discharge equalization mode. Connecting the wrong charging polarity can damage the instrument and possibly cause damage to the charger;
- 7 It is necessary to have personnel monitor the instrument and battery module when equalizing the battery module, and it is strictly prohibited to use it when no one is on duty;
- 8 It is necessary to use the battery pack connection line that is randomly matched with the equalizer. It is prohibited to add or modify the connection line, otherwise the user will be responsible for any accidents caused;
- 9 There are multiple high-voltage circuits and components inside the equalizer, and it is strictly prohibited to disassemble or attempt to modify them. Otherwise, if any accidents occur, the user will be responsible;
- 10 The interior of the equalizer is composed of precision electrical components. The instrument is strictly prohibited from entering water or mist, otherwise it may cause damage to the instrument;

B. General reminder:

- 1 The equalization effect is related to the time and speed of equalization, and the faster the speed, the worse the equalization effect. Suggest setting a smaller balance current value to improve balance accuracy;

- ② The equalizing current marked on the equalizer is the equalizing discharge current of the battery cell at its maximum voltage of 4.2V (ternary lithium battery).The design of the instrument is a constant resistance discharge energy consumption. When the battery voltage decreases or the cell itself is low in voltage, the decrease in equalizing current is a normal phenomenon;(1024 is a 420mΩ constant resistance discharge load) (1524 is a 280mΩ constant resistance discharge load)
- ③ When it is necessary to measure the balanced real-time current, the instrument should be set to the NAX function mode, which is a continuous current state. In this state, the DC clamp meter can measure the zero voltage line or maximum voltage line of the battery module to obtain data; (Equalizers without MAX function are all pulse current during operation, and ordinary current measuring instruments cannot measure the actual current value)
- ④ Because the battery is an electrochemical reaction element, it has the phenomenon of electromotive force (voltage) rise. When the battery unit experiences energy consumption discharge and the amplified current discharge ends, the battery end voltage will increase by a certain amount after disconnecting the load.(For example, after the mobile phone notifies that the battery is low and automatically shuts down, it can be turned on again after a few minutes and a small amount of battery will be displayed), in this case, the user may mistakenly think that the equalization effect is poor. Therefore, it is recommended to use the current to perform fine balancing for a long time to achieve satisfactory results;
- ⑤ Any equalizer cannot equalize and repair on damaged battery packs, including but not limited to the following:
 - a. Increase in battery internal resistance.
 - b. The voltage at the battery end is lower than the discharge termination voltage.
 - c.Short circuit or open circuit inside the battery.
 - d. Damaged battery module BMS (protective board)
- ⑥ Read the user manual of the instrument in detail. If you have any questions, please contact the manufacturer's customer service hotline immediately.

Packing List



Main machine×1pc



Power line×1pc

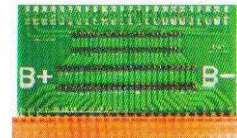

Line sequence test board-24S×1pc

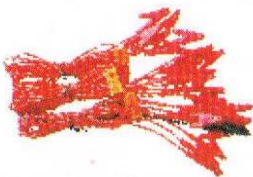

24S output/input terminal ×1pc

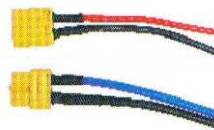

XT-60 interface×2pc
(Battery pack input, Charger Input)



Manual&Warranty Card×1pc

Language Switching *MicroCharge*

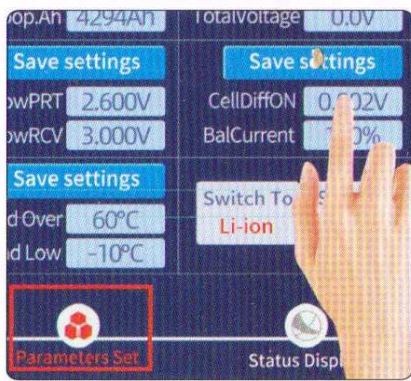

1. Click to enter the parameter interface, click on the balanced pressure difference.

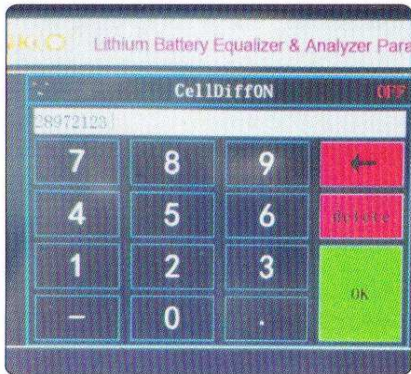

2. Enter the password "28972123" and click "OK" to switch between Chinese and English languages.



3. In English mode, after switching the battery type, restarting the instrument will restore the default factory state.
(Namely: Lithium Battery Mode: Ternary Lithium Language: Chinese)

Manufacturer : Foshan Meilide Electronic Co.,Ltd
Tel : 0757-28972123 / 18988514806
E-mail : mldsunkko@hotmail.com
Website : <https://sunkkowelder.1688.com>
Address : NO.4 Guda Road Zhangcha, Chancheng,
Foshan, Guangdong,China.

Dealer : Tom's Elektronikschmiede
Tel : 05722-981967 / Fax : 05722-981968
E-mail : tom@microcharge.de
Website : <https://www.microcharge.de>
Address : Hauptstraße 35, 31707 Heeßen
Niedersachsen, Deutschland